

CVS

Controls Ltd.

Product Manual

CVS Type 1301F and CVS Type 1301G Regulator

Introduction

This CVS Controls product manual includes instructions for the installation, adjustment, maintenance and parts ordering of the CVS Type 1301F and CVS Type 1301G Regulator.

All CVS Controls equipment should be installed, operated and maintained by qualified personnel. If you have any questions regarding this equipment, contact your CVS Controls representative.

Any leak in the pressure system indicates that service is required. Failure to remove the regulator from service for immediate maintenance may cause a hazardous situation.

Description

The CVS Type 1301F and 1301G Regulator is a self-operated, high-pressure regulator. It is used where high pressure gas must be reduced for use as pilot supply pressure in pilot-operated regulators, or as loading pressure in pressure-loaded regulators. This regulator is also suitable for other applications as high-pressure reducing regulators for various gases.

The CVS Type 1301F is available in three spring ranges to provide outlet pressures to 225 psig (15.5 bar). CVS Type 1301G provides outlet pressures to 500 psig (34.5 bar) in one spring range. Inlet pressures can range up to 6000 psig (411 bar).



*Figure 1: CVS Type 1301F and
CVS Type 1301G Regulator*

Specifications

Refer to Table 1 for complete specifications for the CVS Type 1301F and CVS Type 1301G Regulator. Every regulator which comes from the factory has the maximum outlet pressure stamped on the nameplate (Key 21).

Specifications

End Connections		¼-inch NPT female (one inlet and two outlet connections)	
Maximum Inlet Pressure		6000 psig (414 bar), Air and Gas	
Maximum Emergency Outlet Pressure		Type 1301F	250 psig (17 bar)
		Type 1301G	550 psig (37.9 bar)
Outlet Pressure Ranges		Type 1301F	10 to 75 psig (.07 to 5.2 bar) 50 to 150 psig (3.4 bar to 10.3 bar) 100 to 225 psig (7 bar to 15.5 bar)
		Type 1301G	200 to 500 psig (13.8 to 34.5 bar)
Pressure Registration		Internal	
Temperature Capabilities	Nylon Valve Disk and Neoprene Gaskets	-20 to 180°F (-29 to 82°C)	
	PTFE Valve Disk and Fluorocarbon Gaskets (FKM)	-20 to 400°F (-29 to 204°C) Not recommended for hot water use	
	PTFE Valve Disk and Ethylene-Propylene Gaskets (EPDM)	-65 to 302°F (-54 to 150°C)	
Orifice Port Diameter		5/64-inch (2mm)	
Spring Case Vents	Stainless Steel Spring Case	Type 1301F	One 1/4-inch NPT female connection
		Type 1301G	One 1/8-inch NPT connection
Options		Bracket for mounting regulator on yoke of control valve actuator, or Inlet filter disk	
Approximate Weight		8 pounds (3.6 kg)	

Installation

WARNING

Do not install any pressure equipment where service conditions exceed the manufacturer's specifications. Over pressuring of regulator may result in leakage, equipment damage or personal injury. Excessive pressure can cause the pressure-containing parts to burst, or accumulated gas to explode. Always conform to applicable industry codes and regulations.

Prior to installation check the regulator and all tubing and piping for damage and remove any foreign material.

The regulator can be installed in any position.

WARNING

A regulator may vent some gas into the atmosphere. When used in hazardous gas service, the regulator should be vented to a remote, safe location. If not properly vented, hazardous gas may accumulate and cause fire or explosion.

Prior to being shipped from CVS Controls, the pressure setting for each regulator is set according to customer specifications. If no setting is specified, the outlet pressure is set at the midpoint of the regulator spring range.

If pressure adjustment is required, refer to the "Start Up" section of this guide. Always check the spring section to ensure it is correct for the application.

Begin installation by applying pipe compound to the pipeline threads. Connect inlet piping or tubing to the ¼-inch NPT screwed connection marked "In" as well as outlet piping or tubing to one of the ¼-inch NPT screwed connections marked "Out". Install a pressure gauge or pipe plug in the unused outlet connection.

To maintain continuous operation during inspection or maintenance of the regulator, install a three-valve bypass around the regulator.

Start Up

When the regulator has been installed and downstream equipment has been adjusted, the regulator can be pressurized.

Using gauges to monitor the pressure slowly open upstream and downstream block valves during start up and while performing any adjustments.

If adjustment is required loosen the locknut (Key 11) and turn the adjusting screw (Key 1) either clockwise to increase the set pressure or counter-clockwise to decrease the set pressure. Monitor the pressure during the adjustment using pressure gauges. When the adjustment is complete, tighten the locknut. If the desired outlet pressure is not within the range specified by the regulator spring, refer to the "Maintenance" section of this guide and install the spring that suits the desired range.

Shutdown

To shutdown the regulator, close the upstream shutoff valve, then close the downstream shutoff valve. Open the vent valves between the regulator and the downstream shutoff valve then open the vent between the regulator and the upstream shutoff valve. If vent valves have not been installed, safely bleed off both inlet and outlet pressures and ensure that the regulator contains no pressure.

Maintenance

Regulator maintenance should be done as required by local regulations, and as necessary due to normal wear and tear. Frequency of inspection and parts replacement should be done according to severity of service.

WARNING

Prior to performing any maintenance or disassembly, isolate the regulator from system pressure and relieve all internal pressure. Performing maintenance while the regulator is pressurized could result in injury, equipment damage or explosion of accumulated gas.

Disassembly

These steps describe how to completely disassemble the regulator. To perform inspection or replace parts, complete only the steps necessary for the specific job. Refer to Figure 2 for key numbers unless otherwise indicated.

1. Loosen the locknut (Key 11) and release spring compression by turning the adjusting screw (Key 1) counterclockwise.
2. Remove the bottom cap (Key 9), bottom cap gasket (Key 8) and spring (Key 3).
3. Remove the valve disk assembly (Key 19) from the yoke (Key 17).
4. Remove the valve disk collar (Key 10) from the valve disk assembly.
5. Remove the spring case cap screws (Key 5) and separate the spring case (Key 2) from the regulator body (Key 6).
6. Remove the upper spring seat (Key 12) and spring (Key 3).
7. Refer to Figure 3 and unscrew the diaphragm locknut (Key 4). Remove the diaphragm plate (Key 13), the two diaphragms (Key 13) and the diaphragm plate gasket (Key 7).
8. Remove the yoke screws (Key 15) and lift the lower and upper halves of the yoke out of the body.
9. Unscrew the orifice (Key 18) and examine the seating edge. If the seat is worn or nicked, replace with a new part.

Assembly

These are complete instructions assuming the regulator was fully disassembled. If the regulator was only partially disassembled, start at the appropriate step. Refer to Figure 2 for key numbers.

1. Screw the orifice (Key 18) into the regulator then insert both halves of the yoke (Key 17). Fasten the yoke together with the cap screws (Key 15).
2. The valve disk assembly (Key 19) has two disks (one on each end). Inspect both disks and select which one will be used. Thread the assembly into the yoke so that the disk to be used is against the orifice. Thread the valve disk collar (Key 10) on to the exposed end of the valve disk assembly.
3. Place the bottom cap gasket (Key 8) onto the bottom cap (Key 9), then insert the spring (Key 3) into the bottom cap and thread the assembly into the regulator.
4. Place the body gasket (Key 16) on the regulator body (Key 6).
5. Refer to Figure 3 and place the diaphragm plate gasket (Key 7), the two diaphragms (Key 14) and the diaphragm plate (Key 13) onto the yoke (Key 17). Ensure the diaphragm convolutions are toward the spring and thread the diaphragm locknut (Key 4) onto the yoke.
6. Place the regulator spring (Key 2) and upper spring seat (Key 12) onto the diaphragm plate.
7. Position the spring case (Key 2) over the spring and on the regulator body. Line up the spring case vent or vents, insert the cap screws (Key 5) and tighten them by hand.
8. Thread the adjusting screw (Key 1) and locknut (Key 11) into the spring case so the spring is just slightly compressed. Securely tighten the cap screws (Key 5) and refer to the "Start Up" instructions for proper adjustment procedures.

Parts Ordering

All pertinent information regarding the regulator is stamped on the bottom cap and on the nameplate. Please refer to this information when corresponding with CVS Controls regarding parts or service for your CVS Type 1301F and CVS Type 1301G Regulator.

When ordering replacement parts, please provide the complete part number from the enclosed parts list.

Parts List - CVS Type 1301F

Key	Description	Part Number	
1	Adjusting Screw	CVS1A368728982	
2	Adjusting Screw Locknut	Steel Spring Case	
3	Spring Case (SST)	CVS21A6377X012	
4	Upper Spring Seat, Steel	CVS1B798525062	
5	Spring, Cd pl Steel	0-75 psig (0 to 5.2 bar), Blue	CVS1D387227022
		0-150 PSIG (0 TO 10.3 bar), Cadmium	CVS1B788527022
		0-225 PSIG (0 TO 15.5 bar), Red	CVS1D465127142
6	Spring Case Cap Screw, Steel (6 req'd)	CVS1K764524052	
7	Diaphragm Locknut, Cd pl Steel	CVS1A309324122	
8	Diaphragm Head, Steel Cd pl	CVS1D387325072	
9	Diaphragm Head Gasket	Viton	
10	Machine Screw (2 req'd)	SST, for SST Yoke	
11	Diaphragm, 302 SST, 2 req'd	CVS1D387036012	
12	Body	SST, 1/4" NPT	
13	Body Gasket	Viton	
14	Yoke	SST	
15	Seat Ring, 303 SST	CVS1D3865X0032	
16	Bottom Cap Gasket	SST Bottom Cap, Viton O-Ring	
17	Valve Disk Assembly	SST/Nylon	CVS1D4684000C2
		SST/TFE	CVS1D4684000B2
18	Valve Spring, 302 SST	CVS1D387137022	
19	Bottom Cap	SST	
20	Valve Disc Collar	CVS1D468635032	
21*	Nameplate, SST (Not Shown)	CVS1F1043	
22*	Top Connector, 316 SST (use with SST Yoke only) (Not Shown)	CVS1J926035072	

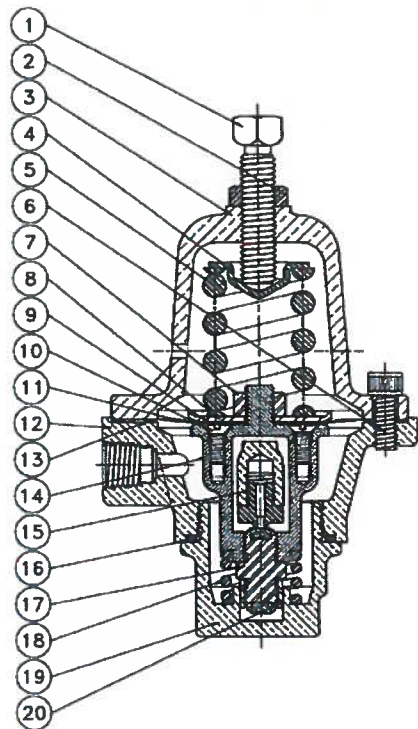

Figure 2: CVS Type 1301F Regulator

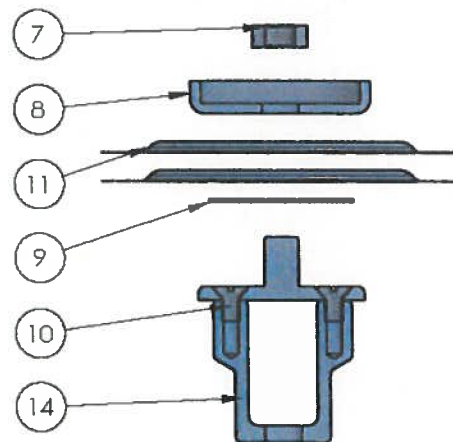

Figure 3: Exploded View of Diaphragm Head Assembly and Yoke

Parts List - CVS Type 1301G

Key	Description	Part Number
1	Adjusting Screw	CVS 1K140624092
2	Adjusting Screw Locknut	CVS1A354024122
3	Spring Case (SST)	CVS21A6377X012-G
4	Upper Spring Seat, Steel	CVS1K155828982
5	Spring, Cd pl Steel	CVS1K156027142
6	Spring Case Cap Screw, Steel (6 req'd)	CVS1K764524052
7	Diaphragm Locknut, Cd pl Steel	CVS1A309324122
8	Diaphragm Head, Steel Cd pl	CVS1K55725072
9	Diaphragm Head Gasket	CVS1D373004122
10	Machine Screw (2 req'd)	CVS1J926938992
11	Diaphragm, 302 SST, 2 req'd	CVS1D387036012
12	Body	CVS2J920033092
13	Body Gasket	CVS1D372904122
14	Yoke	CVS1J925936042
15	Seat Ring, 303 SST	CVS1D3865X0032
16	Bottom Cap Gasket	CVS1J926806382
17	Valve Disk Assembly	SST/Nylon SST/TFE
18	Valve Spring, 302 SST	CVS1D387137022
19	Bottom Cap	CVS1J919635072
20	Valve Disc Collar	CVS1D468635032
21	Nameplate, SST	CVS1F1043
22*	Top Connector, 316 SST (use with SST Yoke only) (Not Shown)	CVS1J926035072

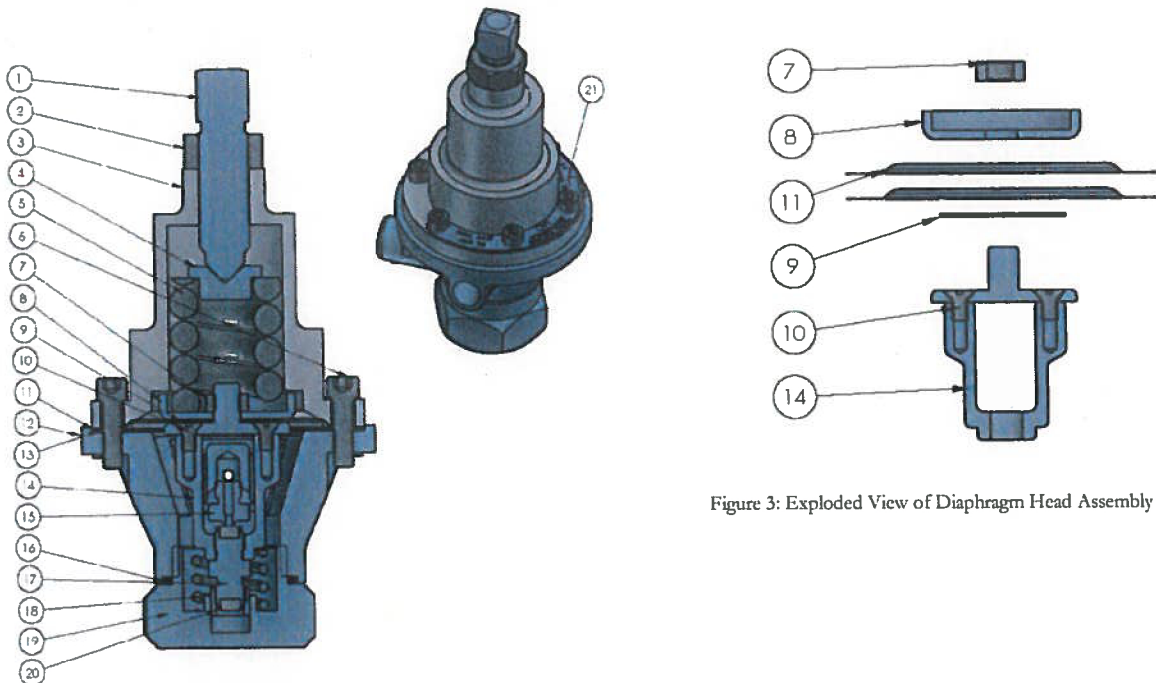

Figure 2: CVS Type 1301G Regulator

Figure 3: Exploded View of Diaphragm Head Assembly and Yoke